

Volvo Construction Equipment  
Building Tomorrow



# ECR25 ELECTRIC

Volvo Electric Compact Excavators 2.7 t



# Adding business by adding Silence

The Volvo ECR25 Electric excavator is a true game changer. The first in a new range of electric compact excavators, it takes a proven concept – and then adds battery electric power, so you'll have all the performance you need, in the compact package you demand. Because we know that being sustainable equals being successful – what's good for people, society and the world is ultimately good for your business.

## At home in the city

The lower noise levels that the ECR25 Electric offers enable you to work anytime, anywhere – even at night in populated areas. This can lessen the disturbance inner city work can cause and reduce congestion at peak times, all the while increasing your efficiency. It also creates a more pleasant working environment for you and your colleagues with whom you can clearly communicate whilst operating.



## Go where others can't

The ECR25 Electric features a zero-tail swing radius design making it perfect to confidently work in confined spaces. And thanks to zero emissions, the need for costly fumes extraction systems is eliminated in indoor jobs, such as basement groundworks and building demolition. This opens up new business opportunities which in turn helps optimize utilization.



## At the heart of operations

The ECR25 Electric takes the proven credentials of the industry's foremost cab – accessibility, visibility and class leading ergonomics – and then adds a substantial reduction in noise, vibration and heat, ensuring long lasting comfort and productivity. The lack of an exhaust is also noticeable, removing the associated fumes and minimizing the dust that they can generate.



## Keep your Volvo a Volvo!

Only with Volvo attachments do you get what you wanted when you bought a Volvo in the first place – maximum productivity and uptime. Volvo develops and offers a wide range of attachments, fully compatible with our electric machines, which brings you unmatched flexibility and versatility, making it easy for you to develop job opportunities and to get the job done with increased productivity.





# ADD SILENCE

Noise pollution is often accepted as part of daily life. At your desk, put on your noise cancelling headphones and just keep going. But that's not a solution for the office worker taking their lunch break in the park. If it's a Volvo ECR25 Electric working close by, it will add some silence back, helping everyone to focus on what's important to them.

# The innovative new ECR25 ELECTRIC

## ZERO EMISSION ELECTRIC POWER

- No emission locally
- Sound level down tremendously
- Maintenance free battery
- Low electricity cost
- No power consumption when machine not working

## NEW LEVELS OF COMFORT

- Low vibration
- Color display with jogwheel navigation
- Intuitive and easier to operate
- Full LED lighting
- Blows less dust



## GET ACCESS TO NEW MARKETS

- Ability to work indoor
- Ability to work out of standard hours
- Ability to work full shift
- Fast charging option

## EVERYTHING YOU'D EXPECT FROM VOLVO

- Monthly greasing only
- Patented hydraulic filter
- Hoses protected inside boom and arm
- Automatic travel speed

## WORK ANYTHING, ANYWHERE

- Same performance as its diesel equivalent
- Ultimate lifting capacity
- Zero-tail swing radius
- Front corner stays within tracks width
- Wide range of Volvo attachments



# Volvo ECR25 Electric in detail

## Electrical system

Battery Type	Lithium-ion	
Battery Voltage	V	48
Battery capacity (full package)	kWh	20
	Ah	450
Indicative runtime (depending on application)	hours	up to 4
Auxiliary Battery Voltage	V	12
Auxiliary Battery capacity	Ah	70
Alternator	V/Ah	12/40

## Electrical motor

Motor type	Permanent magnet	
Motor power (peak)	kW	18
Motor power (continuous)	kW	14.7
Operating mode max. / Standard	r/min	2 050
Operating mode max. / Eco	r/min	1 800
Operating mode max. / Boost	r/min	2 400

## Digging Performances

Standard bucket width (blade, W/O side cutter)	mm	500
Standard bucket mass	kg	59
Standard bucket rated capacity	l	74
Bucket rotation	°	205
Bucket breakout force (ISO)	daN	2 233
Long arm tearout force (ISO)	daN	1 497
With long arm	mm	1 350

## Swing system

Max, slew speed	r/min	9.4
Max, slew torque	daNm	485

## Hydraulic system

Pump type	Variable displacement, load sensing	
Maximum system flow	l/min	58
Maximum flow for accessories	l/min	50
Maximum pressure for accessories	MPa	25
Maximum flow for 2nd accessory circuit	l/min	23
Maximum operating pressure	MPa	25

## Undercarriage

Rubber track width	mm	300
Bottom/top rollers per side	3 / 1	
Track tension	by grease piston	
Blade (width x height)	mm	1 550 x 312

## Travel System

Max, drawbar pull	daN	1 984
Max. travel speed low	km/h	2.4
Max. travel speed high	km/h	4.5
Gradeability	°	30

## Service Refill

Hydraulic system, total	l	33
Hydraulic tank	l	23
Travel reduction unit	l	2 x 0.6

## Sound Level

Interior sound level according to ISO 6396		
L <sub>pA</sub>	dB	74
External sound level according to ISO 6395 and EU Noise Directive (2000/14/EC) and 474-1:2006 +A1:2009		
L <sub>WA</sub>	dB	84

## Weight and Ground Pressure

Operating weight according to ISO 6016	kg	2 730
Ground pressure (cab)	kPa	28.4
Transport weight	kg	2 655
With heated cab		
With direct-fit bucket		
With rubber tracks	mm	300
With long arm	mm	1 350

## LIFTING CAPACITY ECR25 ELECTRIC

These capacities are given for a machine equipped with a cabin, 300 mm rubber tracks and without a bucket or quick-coupler. The below values are in compliance with ISO standard 10567. They do not exceed 75% of the tipping load or 87% of the hydraulic limit with the machine on firm level ground. Loads marked with an asterisk (\*) are limited by machine's hydraulic lifting capacity rather than tipping load. Caution: In accordance with standard EN 474-5, the machine must be equipped to carry out handling operations. It is the operator's obligation to know and follow the applicable national and local safety regulations.

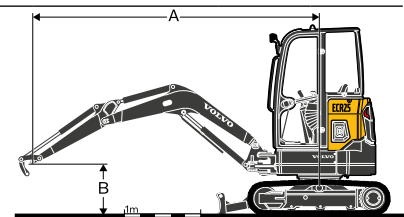

Along undercarriage	Lifting point height (B) m		Lifting point radius (A)									
			2.0 m			3.0 m			Max. reach			Max. m
			↑	↓	↔	↑	↓	↔	↑	↓	↔	
Across undercarriage			↑	↓	↔	↑	↓	↔	↑	↓	↔	
Arm: 1 350 mm Counterweight: standard	2	kg	-	-	-	465	500*	445	294	532*	282	3.971
	1	kg	808	1 334*	760	439	715*	418	269	571*	258	4.142
	0	kg	760	1 608*	713	417	897*	397	278	623*	266	4.002
	-1	kg	763	1 659*	716	413	902*	393	335	692*	320	3.502

# Specifications

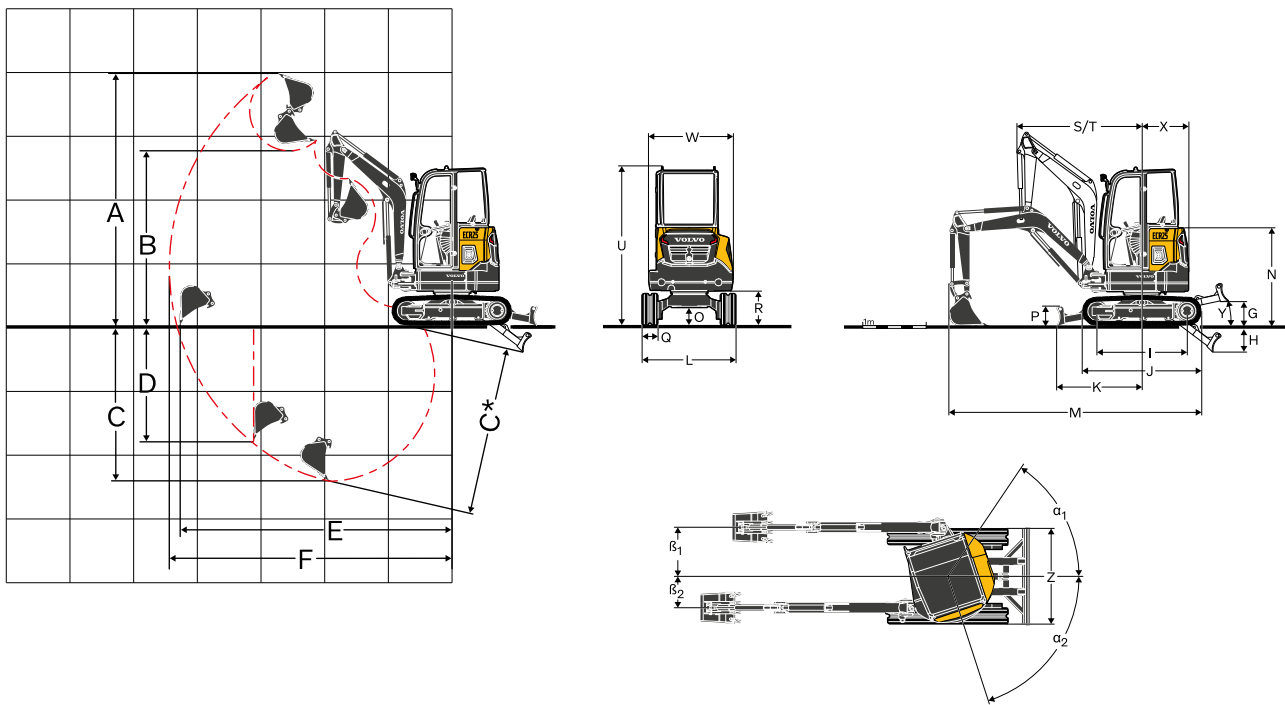

## DIMENSIONS

Description	Unit	ECR25 Electric
<b>Arm</b>	<b>mm</b>	<b>1 350</b>
A Maximum cutting height	mm	4 183
B Maximum dump height	mm	2 957
B* Maximum bucket clearance	mm	3 070
C Digging depth	mm	2 761
C* Maximum digging depth	mm	2 965
D Maximum vertical wall digging depth	mm	2 119
E Maximum digging reach at ground level	mm	4 602
F Maximum digging reach	mm	4 768
G Highest position dozer blade	mm	401
H Lowest position dozer blade	mm	422
I Tumbler length	mm	1 440
J Track length	mm	1 906
K Dozer blade, maximum reach at ground level	mm	1 365
L Overall width with 300mm rubber tracks	mm	1 550
M Overall length	mm	3 876
M* Transport length	mm	4 525
N Overall height of engine hood	mm	1 570
O Minimum ground clearance	mm	290
P Dozer blade height	mm	312
Q Shoe width (rubber)	mm	300
R Ground clearance to superstructure	mm	554
S Front slew radius	mm	2 002
T Front slew radius with maximum offset	mm	1 555
U Overall height cab	mm	2 535
W Overall width of superstructure	mm	1 340
X Tail slew radius	mm	750
Y Angle of approach	°	34
Z Dozer blade width	mm	1 550
$\alpha_1$ Maximum boom swing angle to the left	°	72
$\beta_1$ Maximum boom offset to the right	mm	784
$\alpha_2$ Maximum boom swing angle to the right	°	56
$\beta_2$ Maximum boom offset to the left	mm	496

# Equipment

## STANDARD EQUIPMENT

### Drivetrain

- Axial piston hydraulic motors equipped with an epicyclic reduction gears.
- Automatic two speed travel
- Bottom flanged rollers lubricated for life
- Grease tensioning wheel lubricated for life

### Electric / Electronic control system

- Maintenance free 48V battery (3-rack) - fixed for anti-theft protection
- On-board charger with Type 2 socket
- Standard charger cable with 3 plugs (domestic - white, CEE 16A 1 phase - blue, and CEE 32A 3 phase - Red)
- Fast charger ready with weather protected socket
- Maintenance free 12V auxiliary battery
- High quality connectors
- Protected battery cut-off switch

### Machine exterior

- Warning beacon, flashing LED
- Protected LED worklight on the boom
- Rear LED worklight
- Two LED working lights on top front
- Right and left rear-view mirror
- High visibility orange entrance foot step and handle

### Swing system

- Radial piston hydraulic motor with direct engagement on the ball internal crown wheel (no reduction gears)
- Integrated shockless valve
- Automatic multi-disc spring applied hydraulic released slew brake
- Centralized and remote lubrication of crown wheel & ball bearing

### Undercarriage

- "X" shape, box welded fabricated frame with sloping side members
- 2 Tie-down points on the dozer blade
- 2 Tie-down points on the frame
- 2 lifting points on the frame
- 300 mm rubber tracks
- Sturdy removeable protecting covers for track motors and slew system.
- 400HB weld-on edge on dozer blade

## STANDARD EQUIPMENT

### Hydraulic system

- Plastic tank with drain plug
- Variable displacement, load-sensing piston pump
- Closed centre flow-sharing main control valve
- Cushoning on cylinders:
- Boom up
- Accessory flow adjustment
- Secondary relief valves for auxiliaries
- Hammer / shear valve
- Second accessory circuit
- Flat face hydraulic quick couplings
- Double acting circuit for hydraulic quick couplers
- Mineral hydraulic oil VG46
- Large tiltable oil cooler
- Patented filtering and filling element
- Double-acting hydraulic circuit for accessories

### Cab

- Certified FOPS level 1 on top (Falling Object Protective Structure)
- Certified TOPS (Tip-Over Protective Structure)
- Certified ROPS (Roll-Over Protective Structure)
- Fabric seat, lumbar adjustment, high backrest and retractable seat belt
- High visibility 2" orange seatbelt
- Seat-belt with warning indicator
- Large door access
- Large and roomy uncluttered floor
- Gas-strutt assisted front window opening
- Full opening front bay with in-cab storage for the front lower window.
- Front windscreen wiper and washer nozzle
- Right hand side sliding window
- Flat toughened glass
- Heating systems with in-cab adjustment of temperature and air flow level
- Multiple adjustable air vents
- Filtered air inlet
- Toolbox with integrated storage for operator's manual and lockable door
- Cab inside light
- Cup holder
- Phone holder
- Provision for a radio (antena and electric wiring already fitted)
- In-cab 12V power socket.



---

**STANDARD EQUIPMENT**

---

**Digging equipment**

Monobloc box welded fabricated boom

Boom cylinder rod protection

Integrated lifting point on the boom

Monobloc box welded arms with casted ends

Long-life steel bushings

Hardened, pre-lubricated and corrosion resistant pins

50 hours greasing intervals

Long arm 1 350 mm

---

**Instrumentation and monitoring**

High contrast colour 5" LCD display with day and night modes enabling good readability whatever lighting conditions

Jogwheel for easy navigation and electric motor speed adjustment

3 working modes: Standard, ECO and Boost

Several warning messages, coupled to needed action, in the event of malfunction

Volvo Telematic System

---

**Machine control system**

Finger tip control for boom offset

Finger tip control for auxiliary circuit

Breaker toggle switch on right joystick

Automatic locking device for pilot controls and travel levers when the left console is raised

Electric motor starting safety device: the left console must be raised to operate the starter

Pressure accumulator to lower the equipment on the ground when the engine is switched off

High torque / automatic two speed change over switch on the dashboard

High speed toggle switch on the dozer blade lever

Large travel pedals

---

**Official approval**

Machine conforming to European directive 2006/42/EC

Noise emissions in the environment conforming to directive 2000/14/EC

Hand Arm Vibrations - Whole Body Vibrations compliant with directive 2002/44/EC

Electromagnetic compatibility (EMC) conforming to European directive 2004/108/EC and its amendments

Object handling device conforming to EN 474-1 and EN 474-5 standards

FOPS on top level 1 conforming to ISO 10262 standard

TOPS conforming to ISO 12117 and EN 13531 standards

ROPS conforming to ISO 3471-1 and / SAE J1040 standards

OPG 1 conforming to ISO 10262 standard

OPG 2 conforming to ISO 10262 standard (when equipped)





## Keep it in the family

In addition to compact excavator, the Volvo L25 Electric is the latest evolution from the company that has been at the forefront of wheel loader innovation for over 65 years. It delivers the performance you expect, but with the zero emission electric power you only ever dreamed of. No matter what your application, this electric compact wheel loader will deliver – but in a quieter, cleaner and more comfortable way.

**VOLVO**

**Volvo Construction Equipment**

[volvoce.com](http://volvoce.com)